

Teilleiste:

- 1 x Kiefer Leimholz d=18 510x240 (LxB)
- 1 x Kiefer Leimholz d=18 510x216 (LxB)
- 2 x Kiefer Leimholz d=18 420x240 (LxB)

- 1 x Kiefer Sperrholz d=10 500x500 (LxB)
- 1 x Kiefer Sperrholz d= 8 500x300 (LxB)

- 1 x Leiste Fichte/Tanne 25x20 200 (L)

Seite 1 von 4

5E3 Deluxe

Gehäuse-Bauplan

Alle Angaben in [mm],
wenn nicht anders
angegeben.

Version: 1.8

Datum: 04/08

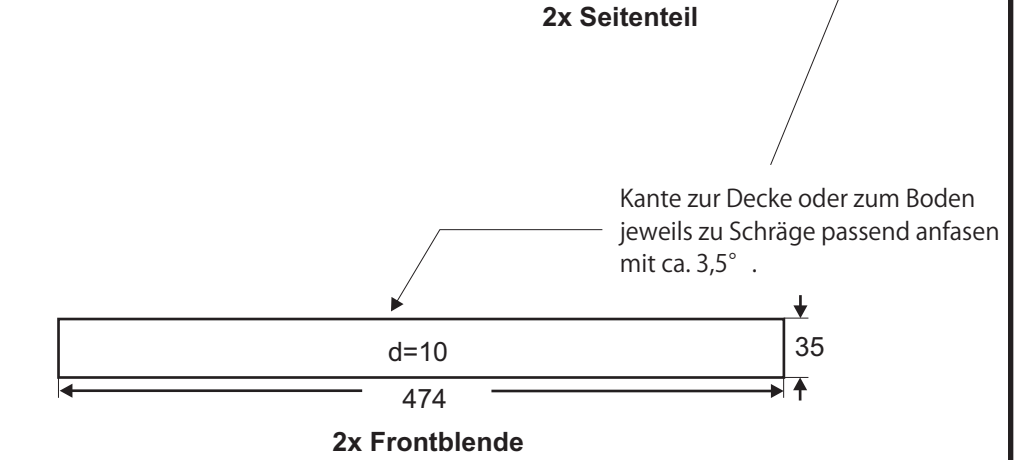
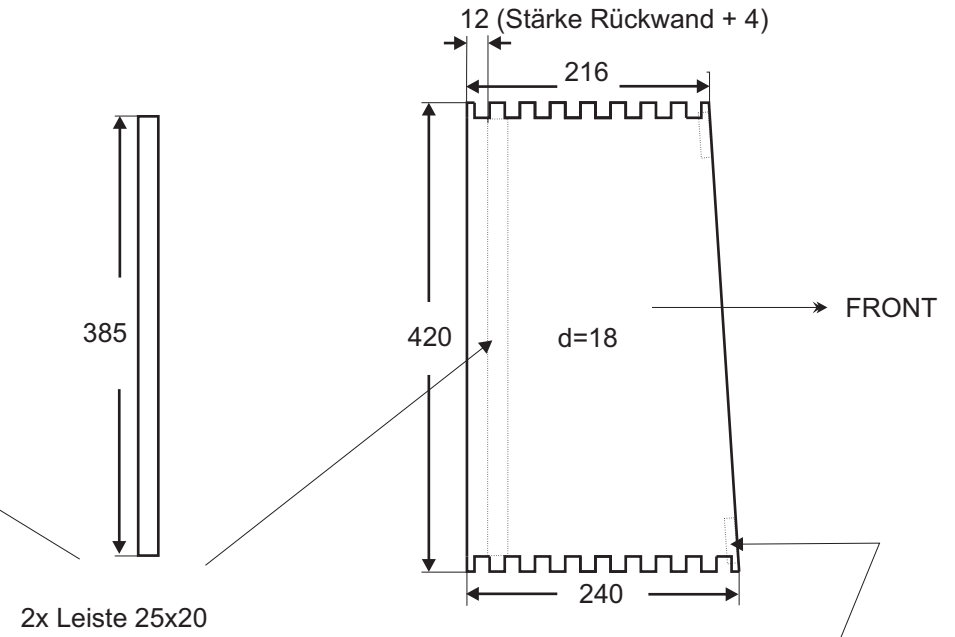
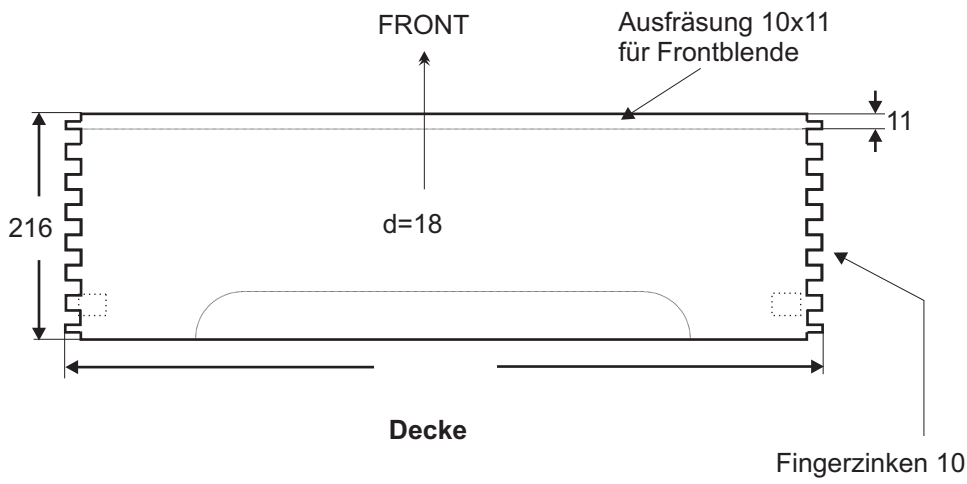
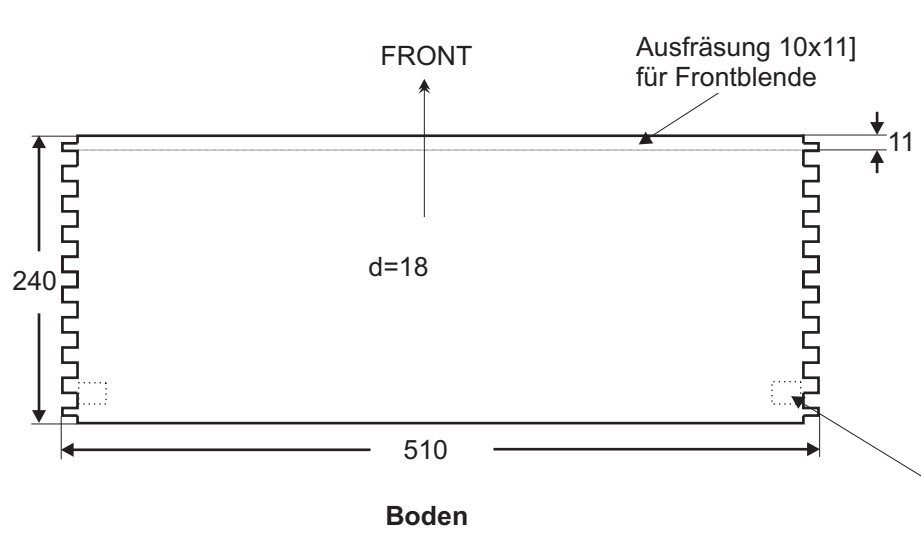

Seite 2 von 4	5E3 Deluxe	
	Gehäuse-Bauplan	
Alle Angaben in [mm], wenn nicht anders angegeben.	Version: 1.8	Datum: 04/08

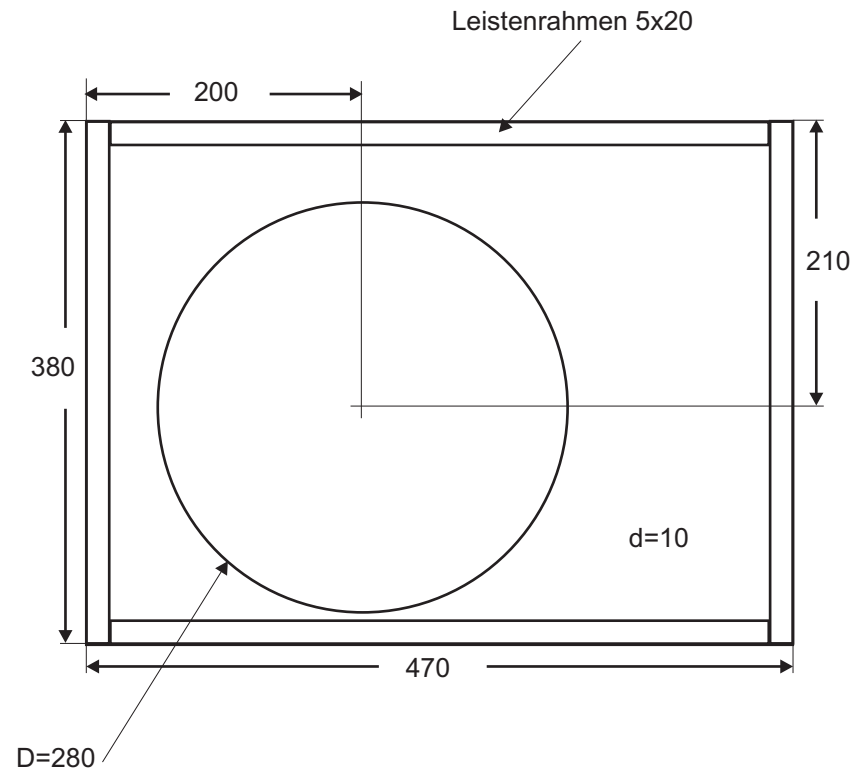
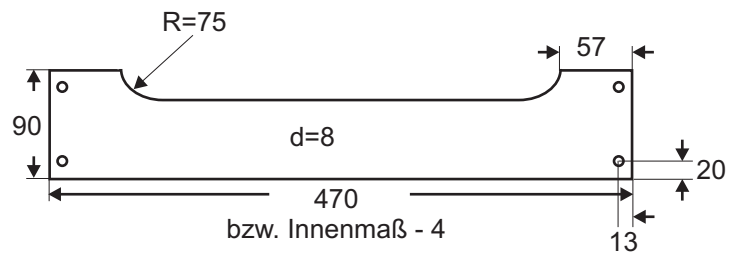
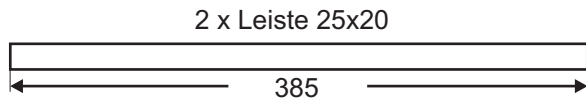
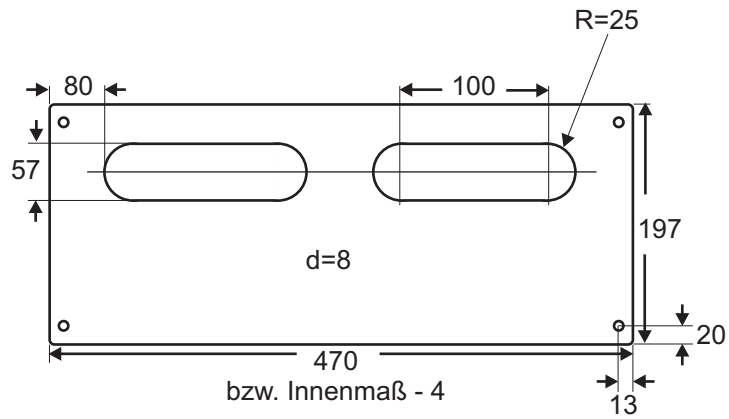

Seite 3 von 4

5E3 Deluxe

Gehäuse-Bauplan

Alle Angaben in [mm],
wenn nicht anders
angegeben.

Version: 1.8

Datum: 04/08

SCHNITTPLAN FÜR TWEED

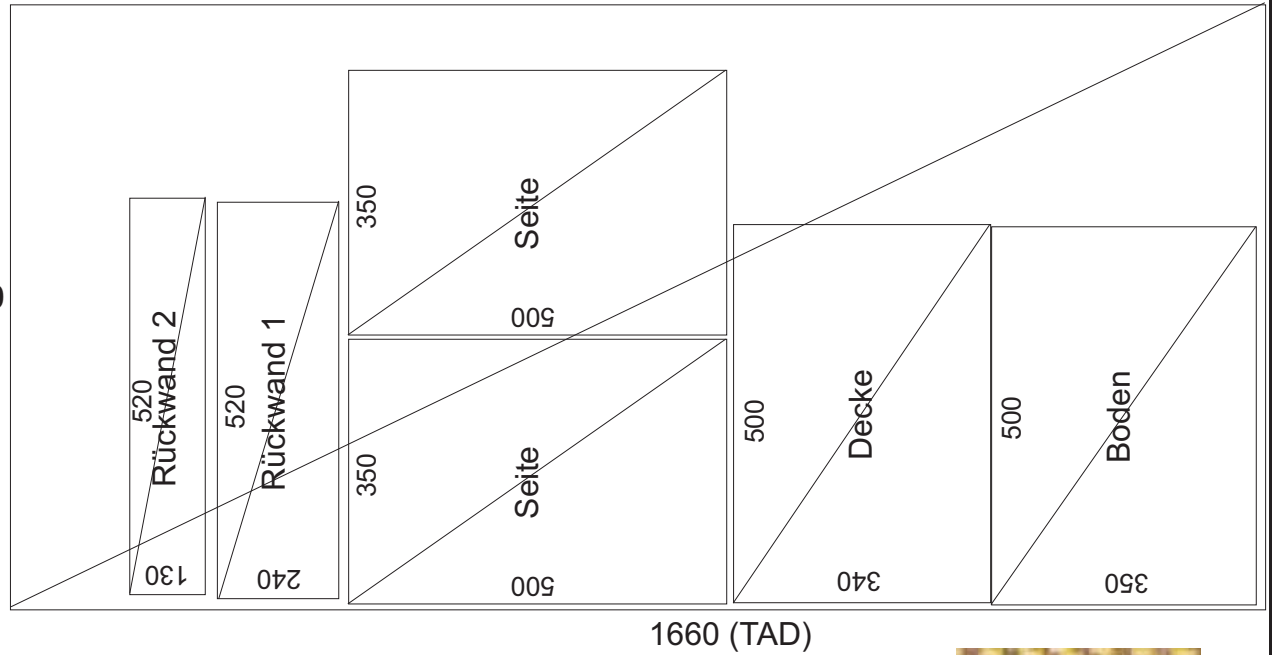
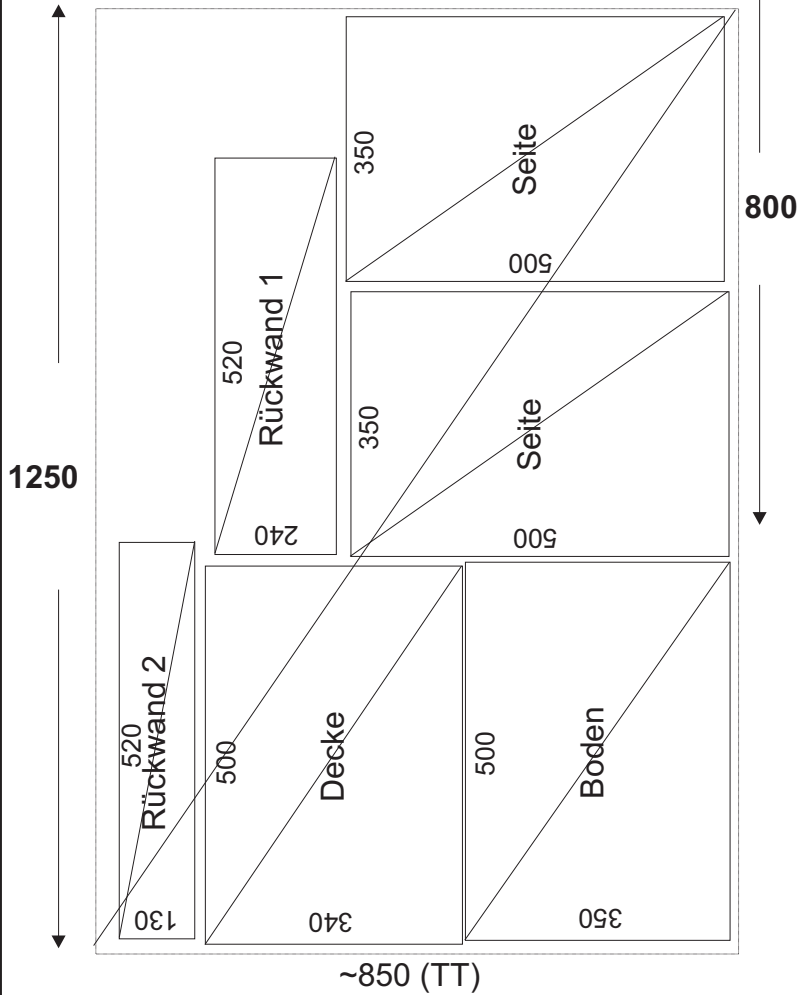

Die schrägen Striche markieren den Musterverlauf.

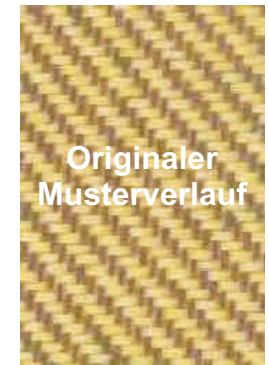

TT: € 32/m b= 850
TAD: € 59/m b=1660

Seite 4 von 4	5E3 Deluxe	
	Gehäuse-Bauplan	
Alle Angaben in [mm], wenn nicht anders angegeben.	Version: 1.8	Datum: 04/08